

B4 DC Systems and Power Electronics
HVDC Networks**AC Faults on HVDC Systems with Modular Multilevel Converters: Impact
Analysis and Configuration Performance**

Alison COTTER
University of Auckland
New Zealand
acot579@aucklanduni.ac.nz

Leyla ZAFARI
University of Auckland
New Zealand
lzaf994@aucklanduni.ac.nz

Nirmal NAIR
University of Auckland
New Zealand
n.nair@auckland.ac.nz

SUMMARY

Voltage Source Converters (VSCs) are becoming the preferred topology for HVDC systems, most popular being Modular Multilevel Converters (MMCs) that provide seamless scalability and can handle higher voltages. Converters like MMCs use multiple submodules interconnected to form upper and lower arms for each AC phase. Some common topologies use half-bridge or full bridge insulated gate bipolar transistor (IGBT) submodules. These MMCs must be capable of fault ride through (FRT) for small AC system disturbances according to most modern grid codes. AC faults are common and can be categorized as symmetrical or asymmetrical. During an AC fault, the converter can experience high currents, voltage imbalances, and fluctuations in the DC link voltage. These fault conditions need to be managed effectively by the converter itself and the control scheme being implemented. Different submodule topologies affect how the converter handles these faults. For instance, full bridge submodules can block DC fault currents, unlike half bridge submodules, making them more desirable during fault conditions. The study focuses on understanding how these different converter topologies and control schemes perform during various AC faults, evaluating their impact on converter behaviour and DC voltage stability.

KEYWORDS

HVDC, Modular Multilevel Converters, AC Faults

1 Introduction

The majority of the world is facing challenges related to an aging transmission network. With power demands increasing with population growth in concentrated urban areas, supplying reliable power to these areas is essential to maintaining functioning society. Along with this, the push for green and renewable energy forces new generation stations to be strategically located geographically for optimal conditions of wind and solar irradiance. This creates an ordeal for sending power from far out generators to the load centres of cities and urban areas. High Voltage Direct Current (HVDC) systems have been proven to be more efficient at longer distances than conventional High Voltage Alternating Current (HVAC). Due to a higher startup cost for HVDC, there is a breakeven distance around 800 km for overhead lines that make HVDC more feasible than HVAC. This breakeven distance is around 50 km for submarine cables. Additionally, there is no way to send AC power to systems running different frequencies. Much of the world operates at 50 Hz, while a few countries have 60 Hz grids. Japan is a unique example of a country that operates at both frequencies. Interconnection of these grids is impossible using traditional AC transmission. HVDC can also be used in this case, to send power across grids of varying frequencies. As HVDC becomes more standard in modern grids, there are more challenges to address within emerging technologies, especially for converters. AC faults remain the most common fault condition, and they can also affect the downstream converter and HVDC link in a variety of ways that will be discussed in this paper.

2 Multilevel Modular Converters

Two main technologies have dominated the HVDC converter market. First being the Line-Commutated Converter (LCC), which is well-developed, and thyristor based. The more modern converter is the Voltage-Source Converter (VSC). VSCs come in a variety of different configurations and have been developing over the last 30 years in HVDC systems. Some of the most common multilevel VSC topologies are IGBT (Insulated Gate Bipolar Transistor) half- and full-bridge converters [1]. These types of VSCs are referred to as Multilevel Modular Converters (MMC) and were introduced in 2006. MMCs are desirable for high-voltage applications since a cascading network of IGBT bridges can be used to increase voltage handling capability.

MMCs consist of interconnected submodules on each arm, for this study, half-bridge and full-bridge topologies will be used. For higher voltage applications, capacitors are used to regulate voltage output. While minimizing capacitance is desirable for cost and volume, submodule (SM) capacitors inherently have a voltage ripple due to continuous charging and discharging during operation; this must be carefully managed to ensure stable operation. Voltage ripples from the capacitor can cause circulating currents within the converter. These currents are impossible to avoid and are typically at double the fundamental frequency of the system. During fault conditions, circulating currents can be amplified causing increased losses and distortion within the systems. Effective control of these internal dynamics, including submodule capacitor voltage balancing, is crucial for the overall reliability and performance of the MMC, especially under faulted grid conditions.

2.1 Half-Bridge Configuration

The half-bridge converter was the first MMC topology used in an HVDC link. The Half-Bridge Sub-Module (HBSM) is the most widely adopted and economically viable MMC submodule structure due to its relatively low cost and minimal power losses during normal operation. However, a major limitation of HBSMs is their inability to block DC fault currents, allowing fault current to flow through their antiparallel diodes from the AC grid. This fundamental characteristic makes HB-MMCs more susceptible to DC faults, creating a need for external DC circuit breakers or AC circuit breakers for effective protection during fault conditions. While AC circuit breakers are a mature technology and generally economical, they have relatively slow response time and can prolong the system's recovery time following a DC fault. Furthermore, HB-MMCs are limited to a modulation index not exceeding unity to ensure high-quality AC power output. This need for external protection for DC faults can impact the overall fault ride-through capability during AC faults indirectly, as the system might need to trip faster or rely more heavily on AC-side protection, potentially affecting grid support.

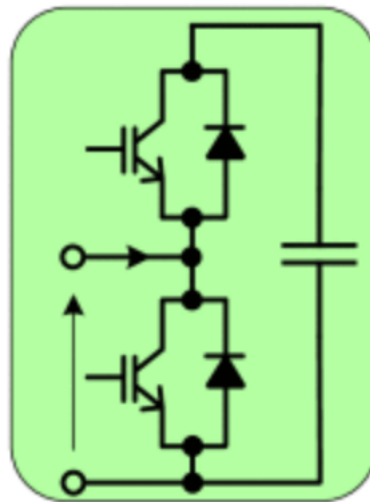

Figure 1 – Half-bridge Submodule [1]

2.2 Full-Bridge Configuration

Compared to the Half-Bridge configuration, Full-Bridge Sub-Modules (FBSMs) offer a major advantage: they can inherently block DC fault current. This is done by generating a negative voltage, which prevents the flow of fault current from the AC side through the converter. This capability allows for non-blocking fault ride through (FRT) during DC faults, allowing the system to continue operation without completely shutting down while reducing stress on the equipment. Although this topology has its benefits there are also some notable disadvantages. Normally, they exhibit almost double the conduction losses and require more components compared to half-bridges. This increase in components and higher losses translate directly into higher manufacturing costs and more operational expenses due to energy dissipation. Despite this, FB-MMCs offer greater operational flexibility, including the ability to operate in a "boost-AC mode" where the modulation index can exceed 1, decoupling the DC and AC voltage levels, and providing more freedom in system design. Additionally, during AC faults, FB-MMCs can inject reactive power into the grid to support the AC voltage. Their ability to output negative voltage levels may provide additional flexibility in managing internal dynamics during severe AC disturbances, potentially creating more robust control over circulating currents and

submodule capacitor voltages. This inherent fault-blocking capability and flexibility make FB-MMCs a more resilient option for AC fault ride-through, although at a higher cost.

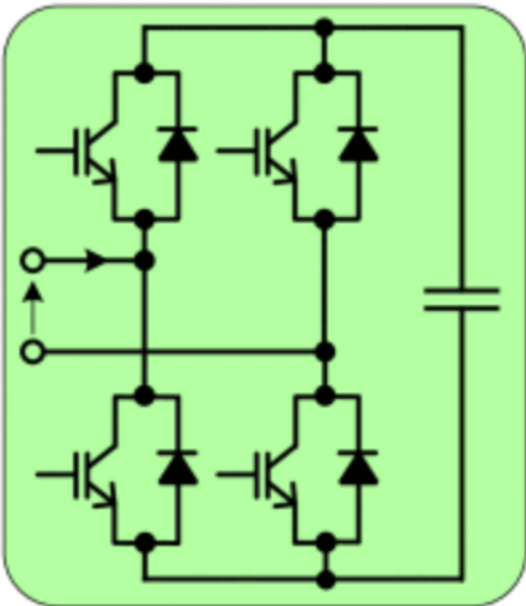

Figure 2 – Full-bridge submodule [1]

3 AC Faults in HVDC Systems

There are two general types of AC faults, symmetric and asymmetric: symmetrical faults encompass faults such as the three-phase short circuit, and asymmetrical faults, which cover single line-to-ground (SLG), line-to-line (LL), and double phase-to-ground (LLG) faults. Single line-to-ground faults are the most common, accounting for approximately 80% of all occurrences in power systems. [2]

The immediate response of an AC fault is a severe voltage dip at the point of common coupling between the AC grid and the MMC terminals. This abrupt reduction in AC voltage directly leads to an instantaneous decrease in the output power capacity of the affected MMC. This reduction in power capacity creates a power mismatch within the HVDC link. While one MMC connected to the fault-side grid may become unable to exchange power effectively, the other MMC at the opposite end of the HVDC link continues to operate normally. This disparity results in fluctuations in the DC link voltage; this could lead to over-voltage or under-voltage conditions. If the fluctuation is severe enough, external protection could be triggered leading to system disconnection or cause permanent damage to the valves within the converter.

Asymmetrical AC faults, in particular, lead to unbalanced capacitor voltages within the opposing arms of the MMC, resulting in an internal energy disparity. This necessitates maintaining the internal energy of both MMCs balanced during AC faults. These internal dynamics also manifest as increased submodule capacitor voltage ripple and circulating currents. If uncontrolled, these can exceed safe limits, causing converter trips and system instability. For symmetrical faults, such as a three-phase short circuit, the transmission power of the converter drops sharply, often approaching zero, leading to a rapid increase in DC voltage, creating distorted waveforms and could cause the AC system currents at the rectifier to collapse to zero. Circulating currents also worsen, typically with double-frequency

components. In contrast, asymmetrical faults like single line-to-ground (SLG) faults cause an AC-side voltage sag and an instantaneous reduction in power capacity, potentially leading to significant second-order oscillations on the DC-link voltage that can propagate to the other converter station, imposing additional voltage stress on semiconductor devices and potentially causing malfunction of protection systems. For LLG faults, the DC voltage is typically observed to experience an increase in its waveform.

4 Common Control Schemes for HVDC Converters

In three-phase AC systems, the circuit can be modelled as a set of three phasors, each shifted by 120 degrees from the others. These three phasors are called positive, negative and zero sequence. Negative sequence current control (NSCC) is a common strategy employed in HVDC systems. When there are unbalanced conditions on the grid, this scheme controls the flow of negative sequence currents. This is implemented through an auxiliary control loop in the MMC and can provide suppression or injection of current to modify the negative sequence. One downside to this control strategy is the ability to cause DC voltage fluctuations during faults, it could also create large over voltages at AC terminals.

Another common method of control in converters is a circulating current suppression or CCSC. The objective is to limit the voltage imbalance within the converter arms that cause circulating current [3]. This is done by injecting voltage into the converter system to compensate the voltage and thus suppress the circulating currents in the system. Typical methods to implement this would be using proportional-resonant (PR) control or model predictive controllers (MPC). PR controllers use high gain at twice the fundamental frequency to cancel the AC component of the circulating current; the output is a compensation voltage injected into the converter arms. MPC uses a more complicated cost function that evaluates several switching states to determine the minimal error for the next time step. Multiple variables can be considered and controlled using MPC schemes. It is also possible to combine the two for a hybrid control system that can block fault current and save budget.

5 Methodology

The systems were modelled using PSCAD CIGRE benchmark models for half-bridge and full-bridge MMC converters on a monopole system. In the two models, sending-end AC faults were examined. First, single line-to-ground faults, the most common fault type, and then the most debilitating faults, three-phase to ground faults, were tested. These fault conditions were examined with and without circulating current suppression control. MMCs can be more seamlessly modelled by using a Thevenin equivalent circuit for several submodules instead of interconnecting many in the software. [5] The simulations were run for 5 seconds with a time step of 250 μ s. The fault was set to occur at 3 seconds, and all simulations looked at sending-end faults, prior to the rectifier.

Table 1 – Initial Conditions

Variable	Initial Value
DC Voltage	300 kV
AC Voltage	220 kV
Real Power	1.0 MW

6 Results & Discussion

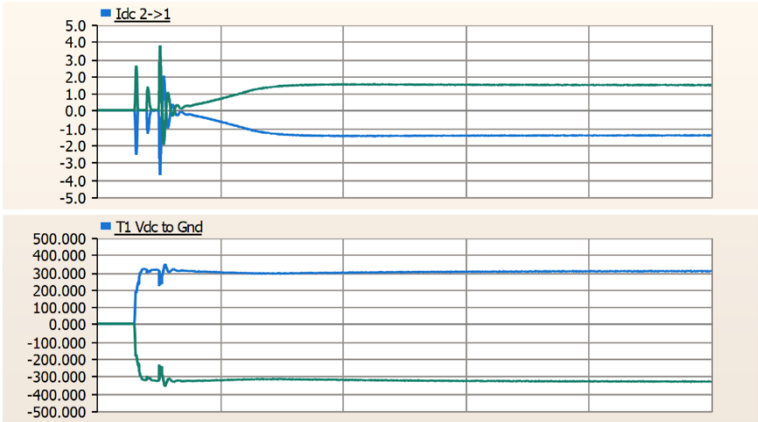

Figure 3 – Normal Operation Idc & Vdc

For normal conditions, there was an initial transient of 1.5 seconds as seen in Figure 3. The discussion will focus on the ongoing stability of the DC voltage and current during and after the fault condition.

6.1 Single-Line to Ground Faults

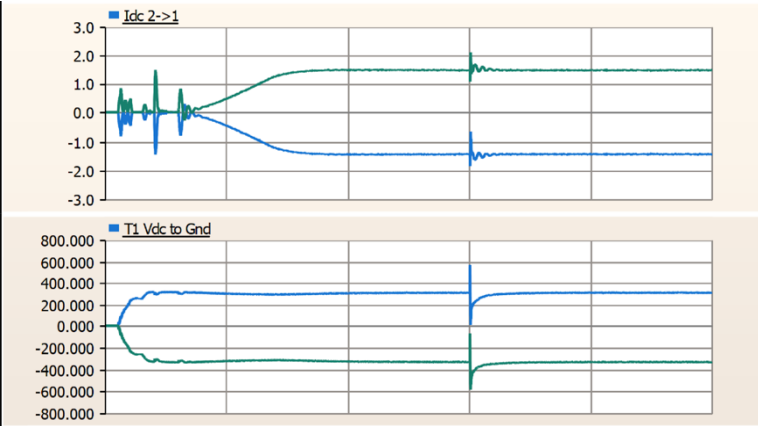

Figure 4 – Single-Line To Ground on Half-Bridge

First, the single-line to ground fault, produced a large jump in the DC voltage in the half-bridge system (Figure 4) as the current on the link fluctuated for 0.3 seconds. This current fluctuation could cause damage to sensitive components and issues and the converter stations as the voltage is almost doubling. For the full-bridge, less severe fluctuations were present allowing the system to continue functioning. This functionality is vital for fault-ride through schemes present in many modern grid codes, especially considering single-line to ground faults are very common.

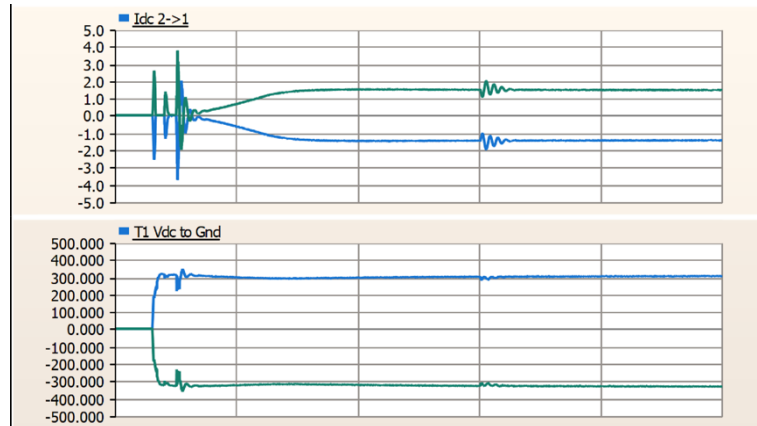

Figure 5 – Single-Line To Ground on Full-Bridge

6.2 Three-Line to Ground Faults

In the three-phase to ground fault, there was a larger difference in the results of each converter topology. Each using circulating current suppression control methods.

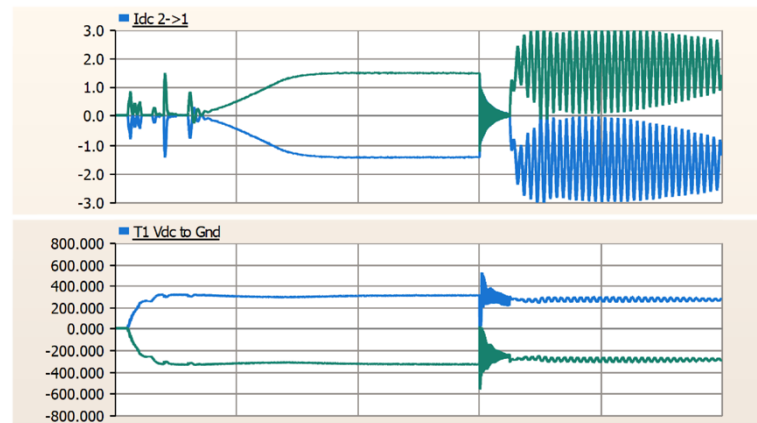

Figure 6 – Three-Line To Ground on Half-Bridge with CCSC

The half-bridge under the same conditions, became unstable and would require shutdown to protect the equipment (Figure 6). Surprisingly, when disabling CCSC as seen in Figure 8, the half-bridge system was able to recover from the three-phase fault. This could have to do with the blocking scheme [4] happening within the system; the simulation trying to run CCSC and blocking concurrently could cause issues. In normal systems, blocking would disable any CCSC scheme as it is the first line of defence to isolate the converter from the fault.

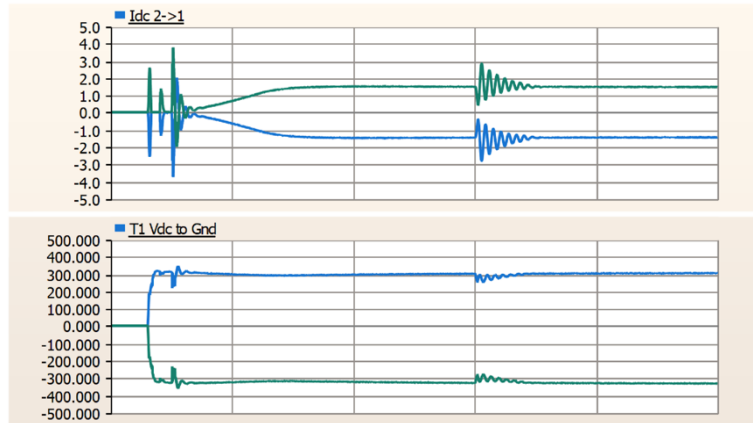

Figure 7 – Three-Line To Ground on Full-Bridge

The simulation shows both systems producing oscillations from the three-phase fault as expected with such a severe fault condition. There is a clear difference in the post-fault operation of the two systems, as the half-bridge goes completely unstable and is unable to recover. The full-bridge remains oscillating for around half a second, but ultimately is able to regain stable operation, showing more resilience in fault ride through overall.

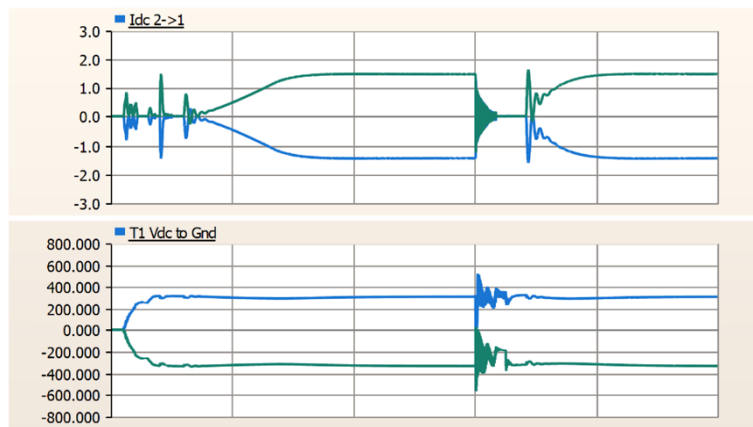

Figure 8 – Three-Line To Ground on Half-Bridge without CCSC

As seen in Figure 8, the half-bridge configuration with CCSC disabled shuts current down to zero similar to Figure 6, on the restart there are small oscillations that degenerate over time, returning to pre-fault conditions. This is likely due to a simulation error as CCSC would help the blocking scheme of the converters during a fault, not allowing for excess current to remain in the converter to prevent damage.

7 Conclusion

This study successfully compared the performance of half-bridge and full-bridge MMCs during symmetrical and asymmetrical AC faults, confirming the superior resilience of the full-bridge topology. The results demonstrate that while half-bridge converters are a cost-effective choice for normal operation, their inability to block DC fault currents makes them highly susceptible to AC faults, leading to severe DC voltage fluctuations that can cause system instability and equipment damage. In contrast, the full-bridge configuration's ability to mitigate fault currents by generating a negative voltage ensures system stability and allows for fault ride-through, which is a requirement in modern grid codes. The surprising finding that the half-bridge system recovered from a three-phase fault when CCSC was disabled highlights a potential area for future research, suggesting a need to investigate the complex interaction between different

control schemes during fault conditions. Ultimately, the choice between these two converter topologies depends on a crucial trade-off between initial cost and long-term operational resilience.

Bibliography

- [1] RM. A. Perez, S. Ceballos, G. Konstantinou, J. Pou and R. P. Aguilera, "Modular Multilevel Converters: Recent Achievements and Challenges," in IEEE Open Journal of the Industrial Electronics Society, vol. 2, pp. 224-239, 2021, doi: 10.1109/OJIES.2021.3060791.
- [2] Jawad, R.S.; Abid, H. HVDC Fault Detection and Classification with Artificial Neural Network Based on ACO- 801 DWT Method. Energies (Basel) 2023, 16, doi:10.3390/en16031064.
- [3] J. -W. Moon, C. -S. Kim, J. -W. Park, D. -W. Kang and J. -M. Kim, "Circulating Current Control in MMC Under the Unbalanced Voltage," in IEEE Transactions on Power Delivery, vol. 28, no. 3, pp. 1952-1959, July 2013, doi: 10.1109/TPWRD.2013.2264496.
- [4] Ziwen Wei, Chen Wang, Yi Wang, Jianye Tao, Zhen Zhang, Tong Xu, "A Novel Bypass MMC Sub-module Topology And Its Capacitor Voltage Balancing Strategy", 2021 IEEE 5th Conference on Energy Internet and Energy System Integration (EI2), pp.874-879, 2021
- [5] A. Beddard and M. Barnes, "Modelling of MMC-HVDC systems an overview," Energy Procedia, vol. 80, pp. 201–212, 2015.